

Panasonic ideas for life

SHORT FORM CATALOG 2008

International



Batteries for OEM Customers

Lithium-Ion, Ni-MH, Lithium, VRLA, Zinc-Carbon, Alkaline, Memory Cards, Battery Packs

SAFETY, LONG-LIFE AND POWER!

PANASONIC BATTERIES



PANASONIC INDUSTRIAL EUROPE FIND OUT HOW WE CAN POWER YOUR BUSINESS!

Matsushita Electric Industrial Co. Ltd., founded in Osaka 1918, is one of the world's largest manufacturers of quality electronic and electrical equipment. Its subsidiary, Panasonic Industrial Europe GmbH (PIE) deals with a wide diversified range of industrial products for all European countries. This company was formed in 1998 to strengthen Panasonic's Pan-European industry operation, and today is active in such different business fields as Car Electronics, Components, Consumer Batteries, OEM/Industrial Batteries etc. to satisfy its customer's needs.

The Industrial Battery Group (IBG) is responsible for the OEM/Industrial Battery business in Europe, with sales offices strategically located throughout the continent. The head office, located in Germany (Hamburg), is responsible for Central Europe (Germany, Benelux, Switzerland, Austria, Scandinavia) and Eastern Europe. The UK/Ireland (Bracknell), France (Paris), Italy (Milano) and Spain (Barcelona) are supported by local offices. In addition, we are able to offer an extensive distributor network. Based on both of these sales channels we are capable of supplying each customer's own power solution.

Find out how we can power your business!

We are able to offer you a wide range of individual power solutions for portable and stationary applications. Our product range includes high reliability batteries such as Lithium-Ion, Lithium, Nickel-Metal-Hydride, Valve-Regulated-Lead-Acid

(VRLA), Alkaline and Zinc-Carbon. Based on this battery range we can power your business in virtually all applications.

Matsushita Battery Industrial Co., Ltd. (MBI) started its production of Panasonic batteries in 1931. Today MBI is the most diversified global battery manufacturer with a network of 23 manufacturing companies in 15 countries. More than 16,000 employees are dedicated to the research and development of new batteries for a new world.

When it comes to production our facilities employ leading edge manufacturing processes meeting the highest quality standards. Our factories are certified to ISO standards. This means that each factory has its own quality and environmental management. The ISO 9000 and ISO 14000 series are the minimum benchmarks that ensure our excellent product reliability.



Panasonic quality – certified by authorised companies.

Furthermore the majority of our factories is also certified to OHSAS 18001 (Occupational Health and Safety Assessment Series), an international standard for assessing a management system for occupational safety. This confirms that the Panasonic factories have been proactive in putting the occupational health and safety of its staff at the centre of the company's dealings. In addition our VRLA batteries are for example approved to German VdS standard and U.S. UL standard.

PIE Organisation Branches

- Home Appliances & Industry Device
- Telecom & Computer Device
- Automotive & General Industry
- Semiconductor
- Industry Battery
- Audio Visual

Holistic sustainability

Wood is capital for human beings, animals and plants. The organisation Programme for the Endorsement of Forest Certification Schemes (PEFC) is working continuously to sustain the ecological equilibrium in our woods. Companies which are certified by PEFC are showing strongly their efforts towards the environment and their responsibility in working with the essential raw material wood. PEFC means holistic sustainability: an integrated concept which combines ecological, social and economical aspects. This Panasonic catalog is printed in compliance with this paper standard.



OUR GOALS



OUR GOALS: SUSTAINABILITY AND RESPONSIBILITY

Panasonic has maintained a commitment to contribute to society through business, based on the belief that “a company is a public entity of society”. We promote environmental initiatives that acknowledge our obligation to preserve the earth’s resources and protect our natural surroundings. One of our main business priorities is to fine-tune an environmentally responsible management style to maintain and nurture the ecology of the planet. We take our social responsibility very seriously and always try to establish a fair and respectful relationship to our employees.

Green products

We concentrate on efforts for making all Matsushita products “green” – e.g. by reducing the usage of chemicals to avoid pollution risks. We are reinforcing green procurement systems and energy saving products and we are aiming at household fuel cells from 2009 onwards.

Clean factories

The effective utilisation of resources during production processes prevents air and water pollution and reduces the amount of waste. Optimised workflows also greatly improve energy efficiency.

Product recycling

The collection and recycling of end-of-life products is a duty which grows ever important in the 21st century. Panasonic started the recycling of home appliances in Japan in 2001.

Communication

It’s an imperative to develop local experts in energy saving conservation technologies. Aiming a sustainability society – this goal is presented at varied eco product fairs by the Matsushita management.

Social responsibility

Panasonic aims to create safe and comfortable working environments. For that reason our Occupational Health and Safety Management has installed various work and life support programs.

Fair business practices

Adherence to legal and ethical standards in all business activities is a major prerequisite for the continued existence of our company. We take these responsibilities very serious.



Corporate citizenship

We want to enrich people's lives and support education – e.g. by teaching elementary and junior high school students how batteries are working. Furthermore Panasonic teamed up with other companies in the US to highlight the importance of recycling products by arranging consumer electronics events.

We support arts and culture – for example with our “Shakespeare for children” series. And we are supporting social welfare as the Fureai Festa for handicapped people.

Moreover this Panasonic has a 15 years cooperation with Remploy Limited in the UK to create and support jobs for people with a range of disabilities.

” What does CSR* mean for Panasonic? ”

*Corporate Social Responsibility

” Contributing to society through our activities in terms of environmental responsibility, fair business practices and occupational safety and health management! ”



NICKEL-METAL-HYDRIDE

CYLINDRICAL More and more electric products with sophisticated functions require extremely compact and lighter battery solutions delivering a high level of energy density. To meet these needs Panasonic Ni-MH batteries have been developed and manufactured with nickel hydroxide for the positive electrode and hydrogen-absorbing alloys, capable of absorbing and releasing hydrogen at high-density levels, for the negative electrode. The Ni-MH battery technology is nowadays some kind of Ni-Cd (nickel cadmium) successor technology for rechargeable and portable devices. All of our Ni-MH batteries are cadmium-free, in order not to be harmful to human beings and our environment.



RECHARGEABLE 1.2 V

| Model Number | Diameter | Size | IEC | Nominal Voltage (V) | Discharge Capacity ^{*1} (mAh) | | Dimensions with Tube (mm) | | Approx. Weight (g) |
|-----------------------------|----------|--------|---------|---------------------|--|--------------|---------------------------|---------------|--------------------|
| | | | | | Average ^{*2} | Rated (min.) | Diameter | Height | |
| HHR-70AAA/FT | AAA | AAA | HR11/45 | 1.2 | 730 | 700 | 10.5 + 0/-0.7 | 44.5 + 0/-1.0 | 12.0 |
| HHR-75AAA/HT ^{*3} | AAA | AAA | HR11/45 | 1.2 | 730 | 700 | 10.5 + 0/-0.7 | 44.5 + 0/-1.0 | 12.0 |
| HHR-80AAA/HT ^{*3} | AAA | AAA | HR11/45 | 1.2 | 780 | 750 | 10.5 + 0/-0.7 | 44.5 + 0/-1.0 | 13.0 |
| HHR-35AA/FT | AA | 2/3AA | - | 1.2 | 390 | 350 | 14.5 + 0/-0.7 | 28.5 + 0/-1.0 | 10.5 |
| HHR-120AA/FT | AA | 4/5AA | HR15/43 | 1.2 | 1,220 | 1,150 | 14.5 + 0/-0.7 | 43.0 + 0/-1.0 | 23.0 |
| HHR-70AA/FT | AA | AA | HR15/51 | 1.2 | 780 | 700 | 14.5 + 0/-0.7 | 48.8 + 0/-1.5 | 21.0 |
| HHR-70AA/HT ^{*4} | AA | AA | HR15/51 | 1.2 | 780 | 700 | 14.5 + 0/-0.7 | 50.5 + 0/-1.5 | 21.0 |
| HHR-110AA/FT | AA | AA | HR15/51 | 1.2 | 1,180 | 1,100 | 14.5 + 0/-0.7 | 50.0 + 0/-1.0 | 24.0 |
| HHR-150AA/FT | AA | AA | HR15/51 | 1.2 | 1,580 | 1,500 | 14.5 + 0/-0.7 | 50.0 + 0/-1.0 | 26.0 |
| HHR-210AA/HT ^{*4} | AA | AA | HR15/51 | 1.2 | 2,080 | 2,000 | 14.5 + 0/-0.7 | 50.5 + 0/-1.0 | 29.0 |
| HHR-260AA/HT ^{*4} | AA | AA | HR15/51 | 1.2 | 2,500 | 2,400 | 14.5 + 0/-0.7 | 50.5 + 0/-1.0 | 30.0 |
| HHR-200A/FT | A | 4/5A | HR17/43 | 1.2 | 2,040 | 2,000 | 17.0 + 0/-0.7 | 43.0 + 0/-1.5 | 32.0 |
| HHR-210A/FT | A | A | HR17/50 | 1.2 | 2,200 | 2,100 | 17.0 + 0/-0.7 | 50.0 + 0/-1.5 | 38.0 |
| HHR-380A/FT ^{*5} | A | L-A | HR17/67 | 1.2 | 3,800 | 3,700 | 17.0 + 0/-0.7 | 67.0 + 0/-1.5 | 53.0 |
| HHR-450A/FT ^{*5} | A | LFat/A | - | 1.2 | 4,500 | 4,200 | 18.2 + 0/-0.7 | 67.0 + 0/-1.5 | 60.0 |
| HHR-200SCP/FT ^{*6} | SC | 4/5SC | - | 1.2 | 2,100 | 1,900 | 23.0 + 0/-1.0 | 34.0 + 0/-1.5 | 43.0 |
| HHR-200SCR/FT ^{*6} | SC | SC | HR23/43 | 1.2 | 2,100 | 1,900 | 23.0 + 0/-1.0 | 43.0 + 0/-1.5 | 48.0 |
| HHR-260SCP/FT ^{*6} | SC | SC | HR23/43 | 1.2 | 2,600 | 2,450 | 23.0 + 0/-1.0 | 43.0 + 0/-1.5 | 55.0 |
| HHR-300SCP/FT ^{*6} | SC | SC | HR23/43 | 1.2 | 3,050 | 2,800 | 23.0 + 0/-1.0 | 43.0 + 0/-1.5 | 57.0 |
| HHR-650D/FT ^{*6} | D | D | HR33/62 | 1.2 | 6,800 | 6,500 | 33.0 + 0/-1.0 | 60.8 + 0/-2.0 | 170.0 |
| HHR-900D/FT ^{*6} | D | D | HR33/62 | 1.2 | 9,000 | 8,250 | 33.0 + 0/-1.0 | 61.0 + 0/-1.5 | 170.0 |

^{*1} After charging at 0.1 CmA for 16 hours, discharging at 0.2 CmA.
^{*2} For reference only.
^{*3} Compatible with consumer AAA size.
^{*4} Compatible with consumer AA size.
^{*5} Mainly for PC applications.
^{*6} For high power use applications such as Powertools.

Applications

E-Bikes, Pedelects, Scooters, Golf-Trolleys, Powertools, Grape-Cutters, Multimeters, Barcode Readers, Handscanners, Labelprinters, Vacuum Cleaners, Muscle electro-stimulations etc.

Features/Technology

- Standard Ni-MH battery technology for nearly every application
- High quality and reliability
- Good balanced batteries in terms of capacity and cycle life
- Excellent discharge characteristics

Model Number (example)

H H R 7 0 A A A / F T

Cap shape: This appendix is used when there is a flat top (HT stands for high top battery).
 Diameter: AAA, AA, A
 Multiply this by 10 to obtain the rated capacity in mAh (some exceptions)
 R = Cylindrical
 Panasonic Nickel-Metal-Hydrate battery

NI-MH • 3D ILLUSTRATION

- 1 Positive pole
- 2 Top plate
- 3 Gasket
- 4 Safety vent
- 5 Collector
- 6 Separator
- 7 Cathode (nickel hydroxide)
- 8 Negative pole (cell can)
- 9 Anode (hydrogen - absorbing alloy)
- 10 Insulation plate
- 11 Exhaust gas hole

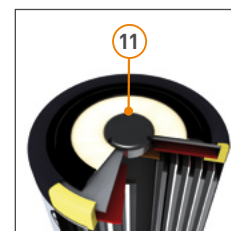

NICKEL-METAL-HYDRIDE

CYLINDRICAL FOR BACK-UP USE The specifically designed Panasonic Ni-MH high temperature battery family is state-of-the-art, providing the batteries with excellent reliability under high ambient temperature and demanding conditions. These batteries give the perfect combination of high power ability and technical expertise.



RECHARGEABLE 1.2 V

| Model Number | Diameter | Size | IEC | Nominal Voltage (V) | Discharge Capacity ^{*1} (mAh) | | Dimensions with Tube (mm) | | Approx. Weight (g) |
|--------------------------------|----------|--------|---------|---------------------|--|--------------|---------------------------|----------------|--------------------|
| | | | | | Average ^{*2} | Rated (min.) | Diameter | Height | |
| HHR-60AAAH/FT | AAA | AAA | HR11/45 | 1.2 | 550 | 500 | 10.5 + 0/-0.7 | 44.5 + 0/-1.0 | 13.0 |
| HHR-70AAH/FT | AA | AA | HR15/49 | 1.2 | 750 | 700 | 14.5 + 0/-0.7 | 48.3 + 0/-1.0 | 18.0 |
| HHR-210AH/FT | A | A | HR17/50 | 1.2 | 2,050 | 1,900 | 17.0 + 0/-0.7 | 50.0 + 0/-1.5 | 37.0 |
| HHR-330APH/FT ^{*4} | A | LFat/A | - | 1.2 | 3,300 | 3,200 | 18.2 + 0/-0.7 | 67.0 + 0/-1.5 | 60.0 |
| HHR-370AH/FT | A | LFat/A | - | 1.2 | 3,700 | 3,500 | 18.2 + 0/-0.7 | 67.0 + 0/-1.5 | 60.0 |
| HHR-250SCH/FT ^{*4} | SC | SC | HR23/43 | 1.2 | 2,650 | 2,500 | 23.0 + 0/-1.0 | 43.0 + 0/-1.5 | 55.0 |
| HHR-300CH/FT ^{*4} | C | C | HR26/50 | 1.2 | 3,300 | 3,100 | 26.0 + 0/-1.0 | 50.0 + 0/-2.0 | 80.0 |
| HHR-1100FH/FT ^{*4} | F | F | HR33/90 | 1.2 | 12,000 | 11,000 | 33.0 + 0/-1.0 | 91.0 + 0/-1.5 | 240.0 |
| HHR-10000VH/FT ^{*3,4} | V | V | - | 1.2 | 95,000 | 90,000 | 62.0 + 0/-1.0 | 173.5 + 0/-1.5 | 1,650.0 |

^{*1} After charging at 0.1 CmA for 16 hours, discharging at 0.2 CmA.
^{*2} For reference only.
^{*3} Customer specification is required. Development concluded but large-scale production not started yet.
^{*4} For high power use applications.

Applications

Combined solar applications,
 Portable medical devices,
 POS terminals,
 Emergency Light for buildings and trains,
 Smoke Detectors,
 Elevator Safety Systems,
 Electronic Toll Collection (ETC) etc.

Features/Technology

- Trickle charge technology
- High charge efficiency at elevated temperatures
- High cycle number
- Long lifetime when using intermittent charge
- Low self discharge

Model Number (example)

H H R - 6 0 A A A H / F T

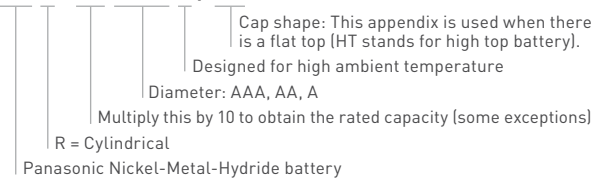

9 V BLOCK The Ni-MH Panasonic 9 V Block provides much higher energy density than comparable Ni-Cd batteries. With its good life cycle performance and no memory effect the 9 V Block is suitable for many applications, such as pagers, toys, multimeters, etc.



RECHARGEABLE 9 V

| Model Number | Diameter | IEC | Nominal Voltage (V) | Discharge Capacity ^{*1} (mAh) | | Dimensions with Tube (mm) | | | Approx. Weight (g) |
|--------------|----------|-----|---------------------|--|--------------|---------------------------|--------|-----------|--------------------|
| | | | | Average ^{*2} | Rated (min.) | Width | Height | Thickness | |
| HHR-9SGE/BA1 | E-Block | - | 8.4 | 170 | 160 | 26.0 | 48.5 | 16.3 | 42.0 |

^{*1} After charging at 0.1 CmA for 16 hours, discharging at 0.2 CmA.
^{*2} For reference only.

Ni-MH BATTERY CHARGER The Panasonic micro-processor-controlled universal battery charger is designed for charging Ni-MH battery packs. This charger is particular optimised for a broad range of Panasonic battery packs.



Features/Technology

- Designed to charge battery packs from 4 to 24 cells
- Optimised for Panasonic batteries
- 3 charge detection criteria: -dU, dT/dt, Tmax
- Charge current: 2.0A DC
- Indication of function by two LEDs
- World-wide approved

LITHIUM-ION

Panasonic is one of the leading Lithium-Ion battery manufacturers in the world. A perfect combination of high-energy density, safety and long life shows what is possible with this battery technology. A continuous co-development with electrical companies all over the world has led to outstandingly good results. Panasonic especially focuses on enhancing safety technologies such as PSS and HRL in order to always guarantee people's safety. Excellent battery safety on one hand, and superior battery performance on the other: this is what Panasonic stands for.



CYLINDRICAL SINGLE CELL

RECHARGEABLE 3.6 V • 3.7 V

| Model Number | Technology | Nominal Voltage (V) | Typical Capacity* ¹ (mAh) | Dimensions (mm) | | Approx. Weight (g) |
|-------------------------|------------|---------------------|--------------------------------------|-----------------|---------------|--------------------|
| | | | | Diameter | Height | |
| CGR-17360A | PSS | 3.6 | 780 | 16.9 + 0/-0.7 | 36.0 + 0/-1.0 | 19.5 |
| CGR-18650CG | PSS | 3.6 | 2,250 | 18.6 + 0/-0.7 | 65.2 + 0/-1.0 | 45.0 |
| CGR-18650DA | PSS + HRL | 3.6 | 2,450 | 18.6 + 0/-0.7 | 65.2 + 0/-1.0 | 45.0 |
| CGR-18650EA | HRL | 3.7 | 2,550 | 18.6 + 0/-0.7 | 65.2 + 0/-1.0 | 46.5 |
| CGR-26650A ² | PSS + HRL | 3.6 | 2,650 | 26.5 + 0/-0.3 | 65.4 + 0/-0.5 | 90.0 |

*1 4.2 V charge
² For high power use applications.

Applications

Laptops,
 Medical equipments,
 Powertools,
 Vacuum Cleaners,
 Shavers, Toothbrushes,
 Web pads, POS terminals,
 Blue tooth pens,
 Hedge trimmers,
 Wireless microphones etc.

Features/Technology

- High energy density and high voltage (3.6 V) lead to small battery dimensions
- Supply long stable power with flat discharge voltage
- A couple of cells are available with PSS- and HRL-technology
- No memory effect
- Use of Lithium-Ion batteries requires use of a safety guard circuit

Model Number (example)

CGR-18650DA

Appendix stands for battery performance characteristics
 Divide this by 10 to obtain the approx. battery height (in mm)
 Stands for approx. diameter (in mm) of the battery
 R = Cylindrical
 Panasonic Lithium-Ion battery

LI-ION • 3D ILLUSTRATION*¹

- 1 Positive pole
- 2 PTC (positive temperature coefficient device)
- 3 Gasket
- 4 Collector
- 5 Insulator
- 6 Cathode
- 7 Anode
- 8 Negative pole (cell can)
- 9 Separator
- 10 CID (current interrupt device)
- 11 Exhaust gas hole

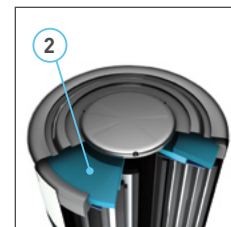

*1 Some batteries are not equipped with a PTC. Please consult Panasonic for further information.

SAFETY TECHNOLOGY*¹

PANASONIC HRL LITHIUM-ION SAFETY TECHNOLOGY

As a power source for mobile and digital equipment essential for a ubiquitous networking society, demand for Lithium-Ion batteries has grown fast. As such equipment including notebook PCs, mobile phones, medical equipment and power-tools become more powerful, sophisticated and feature-laden, they require more robust and safer batteries. Increasing energy-density, however, raises the risk of overheating and igniting due to short-circuiting. Panasonic employs the HRL (Heat Resistant Layer) technology to improve the safety of Lithium-Ion batteries on the one hand and to increase the energy density of these batteries on the other hand. This heat resistance layer consist of an insulating metal oxide on the surface of the electrodes which leads the battery not to overheat even if a short-circuit occurs.

Safety is the base for everything. Higher Energy can be established based on safety technology.

*1 A couple of our batteries are not provided with our HRL technology yet. Please contact Panasonic to be informed about the current situation.

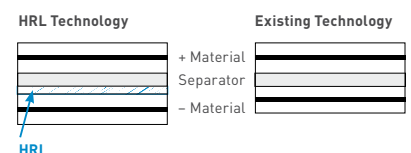

LITHIUM-ION

PRISMATIC SINGLE CELL

RECHARGEABLE 3.7 V

| Model Number | Technology | Nominal Voltage (V) | Typical Capacity* ¹ (mAh) | Dimensions (mm) | | | Approx. Weight (g) |
|--------------|----------------------|---------------------|--------------------------------------|-----------------|---------------|---------------|--------------------|
| | | | | Width | Height | Thickness | |
| CGA-103450A | Lithium Cobalt Oxide | 3.7 | 1,950 | 34.0 + 0/-0.6 | 50.0 + 0/-1.0 | 10.5 + 0/-0.6 | 40.0 |
| CGA-633450B | Lithium Cobalt Oxide | 3.7 | 1,200 | 34.0 + 0/-0.6 | 50.0 + 0/-1.0 | 6.3 + 0/-0.6 | 24.0 |

*1 4.2 V charge

Applications

PDA's,
Portable POS terminals,
Measuring instruments,
Digital Still Cameras,
Handheld scanners,
Barcode readers,
Portable navigation handhelds etc.

Features/Technology

- High energy density and high voltage (3.7 V) leads to small battery dimensions
- Supply long stable power with flat discharge voltage
- No memory effect
- Use of Lithium-Ion batteries requires use of a safety unit device

Model Number (example)

CGA-633450B

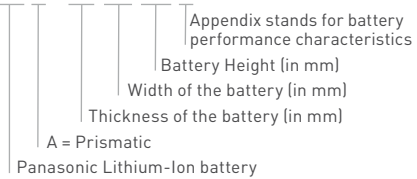

BATTERY PACK (PRISMATIC INSIDE)

RECHARGEABLE 3.7 V

| Model Number | Nominal Voltage (V) | Typical Capacity (mAh) | Dimensions with tube (mm) | | | Approx. Weight (g) |
|--------------|---------------------|------------------------|---------------------------|--------|-----------|--------------------|
| | | | Width | Height | Thickness | |
| CGA-7/120 | 3.7 | 1,200 | 35.2 | 53.0 | 7.0 | 30.0 |
| CGA-E/111 | 3.7 | 1,950 | 35.2 | 53.0 | 11.0 | 44.0 |
| CGA-K/102 | 3.7 | 1,150 | 35.3 | 40.3 | 9.6 | 33.0 |



PSS-TECHNOLOGY

WHAT ABOUT THE PANASONIC LITHIUM-ION PSS-TECHNOLOGY?

Panasonic has developed a Lithium-Ion battery generation by using a **Solid Solution Technology**. Idea: Development of a future oriented Lithium-Ion cell technology which secures a balance of high capacity on the one hand and high safety on the other hand. The goal was to develop a technology which provides the customer with a high capacity such as the standard Panasonic Lithium-Ion (cobalt based) cells and owns a high safety standard like the LiMn_2O_4 (manganese based) Lithium-Ion batteries.*

Characteristics of the new Panasonic PSS driven Lithium-Ion battery:

- Thermal stability of cathode materials leads to high safety
- Same energy density as cobalt-based Lithium-Ion batteries
- Excellent cycle life
- High reliability at high temperature
- Less voltage drop at initial discharge than cobalt based Lithium-Ion batteries
- Same charge voltage as cobalt-based Lithium-Ion batteries

* Panasonic cells must always be equipped with a safety unit in order to avoid human beings accidents.

COMPARISON BETWEEN CAPACITY AND SAFETY OF CATHODE MATERIALS

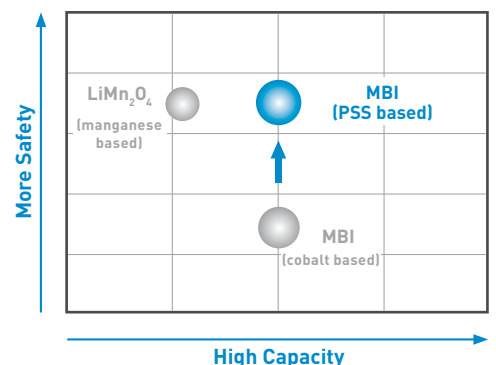

Notice to Readers

We regret to advise that we are unable to support single cell business or accept orders from members of the public. We just design Lithium-Ion battery packs including a suitable safety unit device based on the technical specification of the customer. Due to the need for careful review when selecting Lithium-Ion battery solutions please contact your local Panasonic Sales Office. In order to avoid future embarrassments please check the battery availability with your Panasonic sales team before design-in!

LITHIUM CYLINDRICAL TYPE (PRIMARY)

BR CYLINDRICAL Ever since their market launch in 1973, our Poly-Carbonmonofluoride (BR series) Lithium batteries have accumulated a proven track record and figured prominently as the batteries of choice for varied applications. In particular, their long-term operating performance spanning some ten years has made them the ideal power supply for products such as meters or smoke detectors, and they continue to lead the way in applications that demand long-term reliability.



POLY-CARBONMONOFLUORIDE (BR SERIES) LITHIUM

PRIMARY 3 V

| Model Number ¹ | Electrical Characteristics at 20 °C | | | Dimensions (mm) | | Approx. Weight (g) | IEC |
|---------------------------|-------------------------------------|-------------------------------------|--------------------------------|-----------------|--------|--------------------|---------|
| | Nominal Voltage (V) | Nominal ² Capacity (mAh) | Continuous Standard Drain (mA) | Diameter | Height | | |
| BR-1/2AA ³ | 3 | 1,000 | 2.5 | 14.5 | 25.5 | 8.0 | – |
| BR-AA ^{3,4} | 3 | 2,500 | 2.5 | 14.5 | 50.5 | 15.0 | – |
| BR-2/3A | 3 | 1,200 | 2.5 | 17.0 | 33.5 | 13.5 | BR17335 |
| BR-2/3AG | 3 | 1,450 | 2.5 | 17.0 | 33.5 | 13.5 | BR17335 |
| BR-A | 3 | 1,800 | 2.5 | 17.0 | 45.5 | 18.0 | – |
| BR-AG | 3 | 2,200 | 2.5 | 17.0 | 45.5 | 18.0 | – |
| BR-C | 3 | 5,000 | 5.0 | 26.0 | 50.5 | 42.0 | – |

¹ G indicates higher capacity versions.
² Based on standard drain and cut off voltage down to 2.0 V at 20 °C.
³ This cell is only available with assembled tab.
⁴ Development concluded but large-scale production not started yet.

Applications

Heatcost allocators,
 Water & Gas meters,
 ETC (Electronic Toll Collection) systems,
 Smoke detectors,
 Entry Systems,
 Data Loggers etc.

Features/Technology

- Wide operating temperature range
- Self discharge rate at 20 °C between 0.5 – 1.0% per year
- Superior long-term reliability
- Distinguished production experience

Model Number (example)

BR - 1 / 2 A A

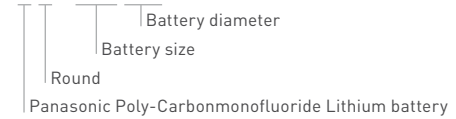

BR CYLINDRICAL TYPE • 3D ILLUSTRATION

- 1 Positive pole
- 2 Positive pole platform
- 3 Jacket
- 4 Cell can
- 5 Collector
- 6 Negative pole
- 7 Insulator
- 8 Anode (lithium)
- 9 Cathode (carbonmonofluoride)
- 10 Separator
- 11 Gasket



PIN TYPE POLY-CARBONMONOFLUORIDE (BR SERIES) LITHIUM

PRIMARY 3 V

| Model Number | Electrical Characteristics at 20 °C | | | Dimensions (mm) | | Approx. Weight (g) | IEC |
|--------------|-------------------------------------|-------------------------------------|--------------------------------|-----------------|--------|--------------------|-----|
| | Nominal Voltage (V) | Nominal ¹ Capacity (mAh) | Continuous Standard Drain (mA) | Diameter | Height | | |
| BR-425 | 3 | 25 | 0.5 | 4.2 | 25.9 | 0.60 | – |
| BR-435 | 3 | 50 | 1.0 | 4.2 | 35.9 | 0.90 | – |



¹ Based on standard drain and cut off voltage down to 2.0 V at 20 °C.

LITHIUM CYLINDRICAL TYPE (PRIMARY)

CR CYLINDRICAL Panasonic Lithium cylindrical batteries type CR come as either single cells or dual cell packs. Pack batteries are packaged in a resin case enabling easy replacement by users. Their development was pioneered by Panasonic. All cylindrical type Manganese Dioxide (CR series) Lithium batteries feature a spiral structure, and by enlarging the surface areas of the positive and negative electrodes they allow a current as high as several amperes to be drawn.



MANGANESE DIOXIDE (CR SERIES) LITHIUM

PRIMARY 3 V - 6 V

| Model Number ¹ | Electrical Characteristics at 20 °C | | | Dimensions (mm) | | Approx. Weight (g) | IEC |
|---------------------------|-------------------------------------|-------------------------------------|--------------------------------|-----------------|--------|--------------------|----------|
| | Nominal Voltage (V) | Nominal ² Capacity (mAh) | Continuous Standard Drain (mA) | Diameter | Height | | |
| CR-2 ¹ | 3 | 850 | 20 | 15.6 | 27.0 | 11.0 | CR15H270 |
| CR-123A ¹ | 3 | 1,400 | 20 | 17.0 | 34.5 | 17.0 | CR17345 |
| 2CR-5 ² | 6 | 1,400 | 20 | 34.0 | 45.0 | 36.0 | 2CR5 |
| CR-P2 ² | 6 | 1,400 | 20 | 35.0 | 36.0 | 37.0 | CR-P2 |
| CR-AAZ ^{1,3} | 3 | 1,700 | 2.5 | 14.5 | 50.5 | 19.0 | CR14500 |
| CR-2/3AZ ¹ | 3 | 1,600 | 2.5 | 17.0 | 33.5 | 17.0 | CR17335 |
| CR-AG ¹ | 3 | 2,400 | 2.5 | 17.0 | 45.5 | 22.0 | CR17450 |
| CR-V3 ¹ | 3 | 3,300 | 200 | 29.0 x 14.5 | 52.0 | 39.0 | - |

¹ Based on standard drain and cut off voltage down to 2.0 V at 20 °C.

² Width Based on standard drain and cut off voltage down to 4.0 V at 20 °C.

³ Development concluded but large-scale production not started yet.

Applications

ETC (Electronic Toll Collection) systems,
Cameras,
High energy flashlights,
RFID tags,
E-Call automotive devices,
Life vests etc.

Features/Technology

- Good Pulse Capability
- High discharge characteristics
- Stable voltage during discharge
- Long-term reliability
- Self discharge rate at 20 °C just 1.0% per year

Model Number (example)

CR - 2 / 3 A Z

Stands for battery performance characteristics
Battery diameter
Battery size
Round
Panasonic Manganese Dioxide Lithium battery

CR CYLINDRICAL TYPE • 3D ILLUSTRATION

- 1 Positive pole
- 2 PTC (positive temperature coefficient device)
- 3 Collector
- 4 Cell can
- 5 Cathode (manganese dioxide)
- 6 Negative pole
- 7 Insulator
- 8 Anode (lithium)
- 9 Separator
- 10 Jacket
- 11 Vent diaphragm



LITHIUM COIN TYPE (PRIMARY)

BR COIN Panasonic Lithium batteries coin type BR feature a high energy density, and were developed and commercialised using Panasonic's extensive experience in battery technology. They exhibit stable performance under relatively high environmental temperatures.



POLY-CARBONMONOFLUORIDE (BR SERIES) LITHIUM

PRIMARY 3 V

| Model Number | Electrical Characteristics at 20 °C | | | Dimensions (mm) | | Approx. Weight (g) | IEC |
|--------------|-------------------------------------|--------------------------------------|--------------------------------|-----------------|--------|--------------------|--------|
| | Nominal Voltage (V) | Nominal ^{*1} Capacity (mAh) | Continuous Standard Drain (mA) | Diameter | Height | | |
| BR-1220 | 3 | 35 | 0.03 | 12.5 | 2.0 | 0.7 | - |
| BR-1225 | 3 | 48 | 0.03 | 12.5 | 2.5 | 0.8 | BR1225 |
| BR-1632 | 3 | 120 | 0.03 | 16.0 | 3.2 | 1.5 | - |
| BR-2032 | 3 | 190 | 0.03 | 20.0 | 3.2 | 2.5 | - |
| BR-2325 | 3 | 165 | 0.03 | 23.0 | 2.5 | 3.2 | BR2325 |
| BR-2330 | 3 | 255 | 0.03 | 23.0 | 3.0 | 3.2 | - |
| BR-3032 | 3 | 500 | 0.03 | 30.0 | 3.2 | 5.5 | BR3032 |

^{*1} Based on standard drain and cut off voltage down to 2.0 V at 20 °C.

Applications

ETC (Electronic Toll Collection) systems,
Varied range of meters,
Memory back-up power supplies,
Electronic notebooks etc.

Features/Technology

- Self discharge rate at 20 °C just 1.0% per year
- Wide operating temperature range
- Superior long-term reliability
- Distinguished production experience

Model Number (example)

BR - 2 3 3 0

Round
Panasonic Poly-Carbonmonofluoride Lithium battery

Divide this by 10 to obtain the battery height in mm
Battery diameter (in mm)

BR COIN TYPE • 3D ILLUSTRATION

- 1 Separator
- 2 Gasket
- 3 Positive pole (cell can)
- 4 Cathode (poly-carbonmonofluoride)
- 5 Anode (lithium)
- 6 Negative pole

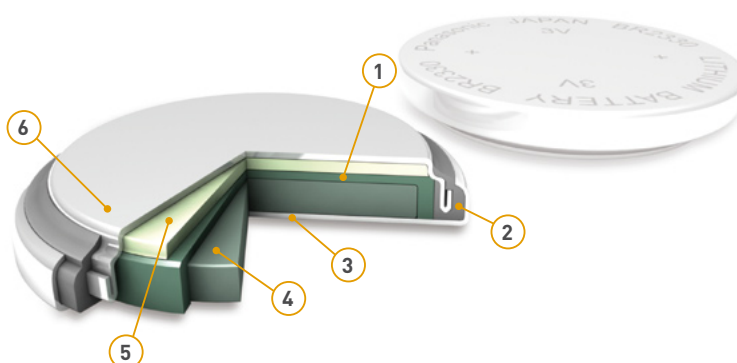

BR COIN "A" SERIES LITHIUM FOR HIGH TEMPERATURE USAGE The materials for the gasket and separator featured in these coin-type Lithium batteries have been replaced with a special engineering plastic and the operating temperature has been significantly increased by employing an electrolyte with a high boiling point. These benefits make this battery series the ideal power supply in high ambient temperature applications.

POLY-CARBONMONOFLUORIDE (BR SERIES) LITHIUM FOR HIGH TEMPERATURE USAGE

PRIMARY 3 V

| Model Number | Electrical Characteristics at 20 °C | | | Dimensions (mm) | | Approx. Weight (g) | IEC |
|--------------|-------------------------------------|--------------------------------------|--------------------------------|-----------------|--------|--------------------|-----|
| | Nominal Voltage (V) | Nominal ^{*1} Capacity (mAh) | Continuous Standard Drain (mA) | Diameter | Height | | |
| BR-1225A | 3 | 48 | 0.03 | 12.5 | 2.5 | 0.8 | - |
| BR-1632A | 3 | 120 | 0.03 | 16.0 | 3.2 | 1.5 | - |
| BR-2330A | 3 | 255 | 0.03 | 23.0 | 3.0 | 3.2 | - |
| BR-2450A | 3 | 600 | 0.03 | 24.5 | 5.0 | 5.9 | - |
| BR-2477A | 3 | 1,000 | 0.03 | 24.5 | 7.7 | 8.0 | - |

^{*1} Based on standard drain and cut off voltage down to 2.0 V at 20 °C.

LITHIUM COIN TYPE (PRIMARY)

Applications

Tire Pressure Monitoring Systems (TPMS),
Water Meters,
Heat cost allocators,
Memory back-up power supplies in high,
ambient temperature applications etc.

Features/Technology

- Superior designed for high temperature applications
- Outstanding long-term reliability
- Distinguished production experience
- Self discharge rate at 20 °C between 0.5–1.0% per year

Model Number (example)

BR - 2 4 7 7 A

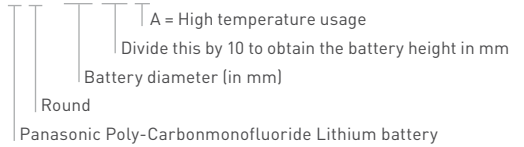

BR COIN "A" TYPE • 3D ILLUSTRATION

- 1 Negative pole
- 2 Separator
- 3 Cathode (poly-carbonmonofluoride)
- 4 Positive pole (cell can)
- 5 Gasket
- 6 Anode (lithium)

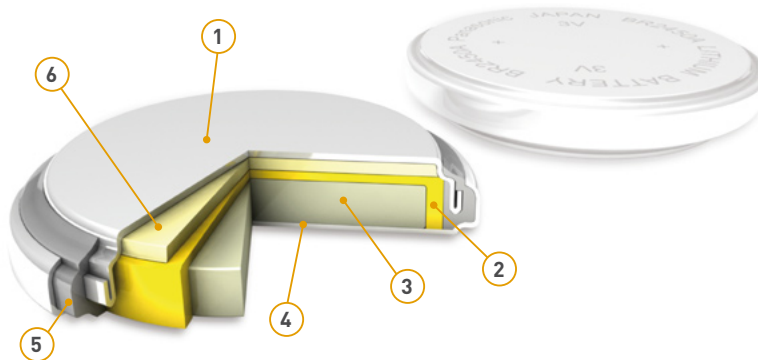

CR COIN As with the BR series of coin-type Lithium batteries, these Panasonic Lithium coin-type CR batteries feature a high-energy density, and they were developed and commercialised using Panasonic's extensive experience in battery technology. These batteries have proven to be especially useful in equipment requiring relatively high currents.



MANGANESE DIOXIDE (CR SERIES) LITHIUM

PRIMARY 3 V

| Model Number | Electrical Characteristics at 20 °C | | | Dimensions (mm) | | Approx. Weight (g) | IEC |
|--------------|-------------------------------------|--------------------------------------|--------------------------------|-----------------|--------|--------------------|--------|
| | Nominal Voltage (V) | Nominal ¹⁾ Capacity (mAh) | Continuous Standard Drain (mA) | Diameter | Height | | |
| CR-1025 | 3 | 30 | 0.10 | 10.0 | 2.5 | 0.7 | CR1025 |
| CR-1216 | 3 | 25 | 0.10 | 12.5 | 1.6 | 0.7 | CR1216 |
| CR-1220 | 3 | 35 | 0.10 | 12.5 | 2.0 | 1.2 | CR1220 |
| CR-1612 | 3 | 40 | 0.10 | 16.0 | 1.2 | 0.8 | - |
| CR-1616 | 3 | 55 | 0.10 | 16.0 | 1.6 | 1.2 | CR1616 |
| CR-1620 | 3 | 75 | 0.10 | 16.0 | 2.0 | 1.3 | CR1620 |
| CR-1632 | 3 | 140 | 0.10 | 16.0 | 3.2 | 1.8 | - |
| CR-2012 | 3 | 55 | 0.10 | 20.0 | 1.2 | 1.4 | CR2012 |
| CR-2016 | 3 | 90 | 0.10 | 20.0 | 1.6 | 1.6 | CR2016 |
| CR-2025 | 3 | 165 | 0.20 | 20.0 | 2.5 | 2.5 | CR2025 |
| CR-2032 | 3 | 220 | 0.20 | 20.0 | 3.2 | 3.1 | CR2032 |
| CR-2330 | 3 | 265 | 0.20 | 23.0 | 3.0 | 4.0 | CR2330 |
| CR-2354 | 3 | 560 | 0.20 | 23.0 | 5.4 | 5.9 | CR2354 |
| CR-2412 | 3 | 100 | 0.20 | 24.5 | 1.2 | 2.0 | - |
| CR-2450 | 3 | 620 | 0.20 | 24.5 | 5.0 | 6.3 | CR2450 |
| CR-2477 | 3 | 1,000 | 0.20 | 24.5 | 7.7 | 10.5 | - |
| CR-3032 | 3 | 500 | 0.20 | 30.0 | 3.2 | 7.1 | CR3032 |

¹⁾ Based on standard drain and cut off voltage down to 2.0 V at 20 °C.

LITHIUM COIN TYPE (PRIMARY & RECHARGEABLE)

Applications

Keyless Entry,
RFID,
Price tags,
ETC (Electronic Toll Collection) systems,
Electronic notebooks,
Back-up for vending machines etc.

Features/Technology

- Good Pulse Capability
- High discharge characteristics
- Stable voltage during discharge
- Long-term reliability
- Self discharge rate at 20°C just 1.0% per year

Model Number (example)

CR - 2 0 3 2

Divide this by 10 to obtain the battery height in mm
Battery diameter (in mm)
Round
Panasonic Manganese Dioxide Lithium Battery

CR COIN TYPE • 3D ILLUSTRATION

- 1 Separator
- 2 Gasket
- 3 Cathode (manganese dioxide)
- 4 Positive pole (cell can)
- 5 Anode (lithium)
- 6 Negative pole

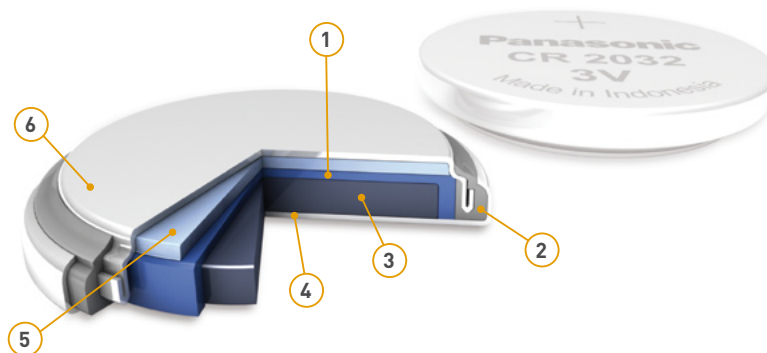

VL, ML, NBL, MT COIN These Panasonic rechargeable Lithium coin batteries are mostly designed for memory back-up applications such as pagers, mobile phones, watches, data terminals and fax machines. Their voltage span ranges from 1.5 V to 3 V.

VANADIUM PENTOXIDE LITHIUM (VL SERIES)

RECHARGEABLE 3 V

| Model Number | Electrical Characteristics at 20 °C | | | Dimensions (mm) | | Approx. Weight (g) | IEC |
|--------------|-------------------------------------|--------------------------------------|--------------------------------|-----------------|--------|--------------------|-----|
| | Nominal Voltage (V) | Nominal ¹⁾ Capacity (mAh) | Continuous Standard Drain (mA) | Diameter | Height | | |
| VL-621 | 3 | 1.5 | 0.10 | 6.80 | 2.1 | 0.27 | - |
| VL-1220 | 3 | 7.0 | 0.03 | 12.5 | 2.0 | 0.8 | - |
| VL-2020 | 3 | 20.0 | 0.07 | 20.0 | 2.0 | 2.2 | - |
| VL-2320 | 3 | 30.0 | 0.10 | 23.0 | 2.0 | 2.7 | - |
| VL-2330 | 3 | 50.0 | 0.10 | 23.0 | 3.0 | 3.5 | - |
| VL-3032 | 3 | 100.0 | 0.20 | 30.0 | 3.2 | 6.2 | - |

¹⁾ Based on standard drain and cut off voltage down to 2.5 V at 20 °C.

MANGANESE LITHIUM (ML SERIES)

RECHARGEABLE 3 V

| Model Number | Electrical Characteristics at 20 °C | | | Dimensions (mm) | | Approx. Weight (g) | IEC |
|--------------|-------------------------------------|--------------------------------------|--------------------------------|-----------------|--------|--------------------|-----|
| | Nominal Voltage (V) | Nominal ¹⁾ Capacity (mAh) | Continuous Standard Drain (mA) | Diameter | Height | | |
| ML-414 | 3 | 1.2 | 0.005 | 4.8 | 1.4 | 0.09 | - |
| ML-421 | 3 | 2.3 | 0.003 | 4.8 | 2.1 | 0.10 | - |
| ML-612 | 3 | 2.6 | 0.010 | 6.8 | 1.2 | 0.15 | - |
| ML-614 | 3 | 3.4 | 0.010 | 6.8 | 1.4 | 0.17 | - |
| ML-616 | 3 | 2.9 | 0.010 | 6.8 | 1.6 | 0.20 | - |
| ML-621 | 3 | 5.0 | 0.010 | 6.8 | 2.1 | 0.23 | - |
| ML-920 | 3 | 11.0 | 0.030 | 9.5 | 2.0 | 0.40 | - |
| ML-1220 | 3 | 17.0 | 0.030 | 12.5 | 2.0 | 0.80 | - |
| ML-2020 | 3 | 45.0 | 0.130 | 20.0 | 2.0 | 2.20 | - |

¹⁾ Based on standard drain and cut off voltage down to 2.0 V at 20 °C.

LITHIUM COIN TYPE (RECHARGEABLE)

NIOBIUM LITHIUM (NBL SERIES)

RECHARGEABLE 2 V

| Model Number | Electrical Characteristics at 20 °C | | | Dimensions (mm) | | Approx. Weight (g) | IEC |
|--------------|-------------------------------------|--------------------------------------|--------------------------------|-----------------|--------|--------------------|-----|
| | Nominal Voltage (V) | Nominal ¹⁾ Capacity (mAh) | Continuous Standard Drain (mA) | Diameter | Height | | |
| NBL-414 | 2 | 1 | 0.008 | 4.8 | 1.4 | 0.10 | - |
| NBL-621 | 2 | 4 | 0.010 | 6.8 | 2.1 | 0.22 | - |

¹⁾ Based on standard drain and cut off voltage down to 1.0 V at 20 °C.

MANGANESE TITANIUM LITHIUM (MT SERIES)

RECHARGEABLE 1.5 V

| Model Number | Electrical Characteristics at 20 °C | | | Dimensions (mm) | | Approx. Weight (g) | IEC |
|--------------|-------------------------------------|--------------------------------------|--------------------------------|-----------------|--------|--------------------|-----|
| | Nominal Voltage (V) | Nominal ¹⁾ Capacity (mAh) | Continuous Standard Drain (mA) | Diameter | Height | | |
| MT-516 | 1.5 | 1.15 | 0.05 | 5.8 | 1.6 | 0.15 | - |
| MT-616 | 1.5 | 1.05 | 0.05 | 6.8 | 1.6 | 0.20 | - |
| MT-621 | 1.5 | 2.50 | 0.05 | 6.8 | 2.1 | 0.25 | - |
| MT-920 | 1.5 | 5.00 | 0.10 | 9.5 | 2.0 | 0.45 | - |

¹⁾ Based on standard drain and cut off voltage down to 1.0 V at 20 °C.

Applications

Computers, Keyless Entry, Fax machines, Mobile phones, Watches etc.

Features/Technology

- Rechargeable Lithium technology
- Self discharge rate at 20 °C is only 2.0% per year for VL, ML and NBL battery types
- 1000 charge-discharge cycles for VL, ML and NBL at 10% depth of discharge
- Superior long-term reliability
- Distinguished production experience

VL COIN TYPE • 3D ILLUSTRATION

- 1 Separator
- 2 Gasket
- 3 Positive pole (cell can)
- 4 Cathode (vanadium pentoxide)
- 5 Negative pole
- 6 Anode (lithium aluminium alloy)

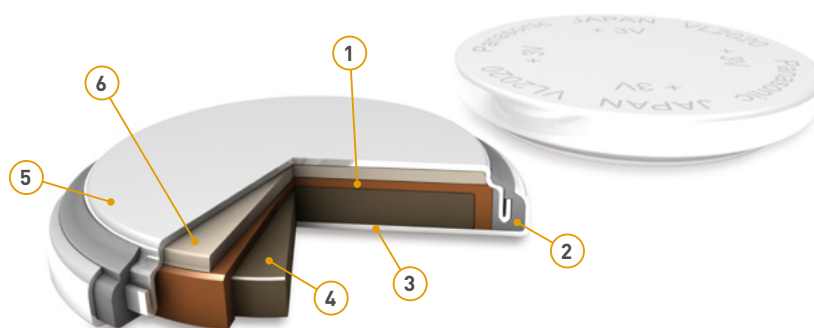

Panasonic offers a broad range of different tabs in order to meet all customer needs.

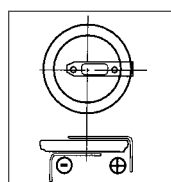

H Type

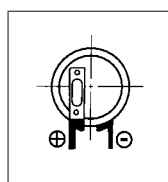

V Type

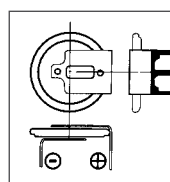

G Type

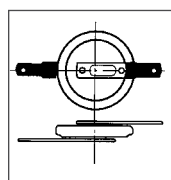

T Type

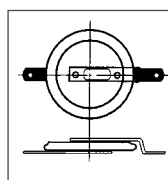

F Type

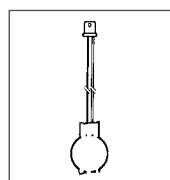

S Type

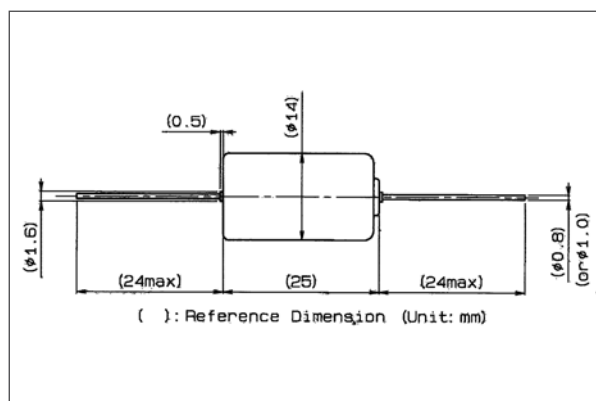

BR-1/2AA with Axial Pin Terminal



LITHIUM BATTERIES WITH INNOVATIVE BR AND CR TECHNOLOGIES

With its range of extremely high power cylindrical Lithium batteries, Panasonic has extended its offer for the markets of measuring instruments, data acquisition and identification (RFID), electronic toll collection systems for cars and lorries (ETC) and safety engineering. They are extremely long-lasting (BR series), feature top pulse currents (CR series) with a 3-volt voltage depending on the design-in.

The two new models BR-1/2AA and BR-AA have capacities of 1,000 and 2,500 milli-ampere hours (mAh) at a nominal voltage of three volts. The Poly-Carbonmonofluoride technology ensures a self-discharge rate below 0.5 percent per year (at room temperature), in addition the batteries can be used in a particularly wide temperature range of between -40°C and $+85^{\circ}\text{C}$.

The three models from the CR series feature capacities of 1,600 mAh (CR-2/3AZ), 1,700 mAh (CR-AAZ) and 2,400 mAh (CR-AG) also at a nominal voltage of three volts. Here, too, the self-discharge rate of one percent per year is very low, whereby the batteries are designed more with applications that have a high pulse current in mind.

With its wide range including not only cylindrical types but also coin cells, Panasonic offers the ideal model for every field of application. A particularly distinguishing feature of Panasonic's Lithium technology is the fact that no "passivation" occurs: operating voltage remains constant over a long period of time guaranteeing that devices run on

these batteries function properly. In practice the failure rate of Panasonic batteries is almost zero.

The new Lithium batteries are ideally suited for long-term applications, e.g. in smoke detectors, car alarm systems or also measuring devices such as water meters or heat cost allocators, as their high degree of reliability reduces the time and effort required for frequent exchanges.

Other areas of application include Electronic Toll Collect Systems (ETC) where the on-board-units are equipped with these long-life batteries, as well as logistic applications using RFID units for identifying goods and storing data. In medical applications these batteries are used in blood glucose meters, defibrillators or infusion pumps. Panasonic Lithium batteries (BR or CR technologies) are also ideal for marine technology applications such as automatic emergency radio buoys, manover-board devices or for the illumination of life jackets.

DRY CELL

ALKALINE The cylindrical Panasonic Alkaline battery is composed of manganese dioxide (+), zinc powder (-) and caustic alkali (potassium hydroxide) as electrolyte. These Alkaline batteries are made from the same basic materials as Zinc-Carbon batteries, but their performance is generally higher for all criteria. All things considered we can say that this Alkaline technology offers a high-performance battery for higher standard applications.



Capacity increased!

PRIMARY 1.5 V · 9 V

| Model Number | Size | Nominal Voltage (V) | Dimensions (mm) | | Approx. Weight (g) |
|--------------|------|---------------------|-----------------|--------|--------------------|
| | | | Diameter | Height | |
| LR03 | AAA | 1.5 | 10.5 | 44.5 | 11.2 |
| LR6 | AA | 1.5 | 14.5 | 50.5 | 23.3 |
| LR14 | C | 1.5 | 26.2 | 50 | 69.5 |
| LR20 | D | 1.5 | 34.2 | 61.5 | 142.7 |
| 6LR61 | 9V | 9 | 17.5 x 26.5 | 48.5 | 44.3 |

Applications

Smoke Detectors, Toys, Marine devices, Medical equipment, Blood Pressure Meters, Analogue Cameras, Portable Audio Devices, High energy flashlights etc.

Features/Technology

- Developed for high and medium drain appliances
- Continuously reliable energy provision
- Long shelf life
- Excellent leakage resistance
- Superior low temperature behaviour

LR ALKALINE • 3D ILLUSTRATION

- 1 Positive pole
- 2 Cathode (manganese-dioxide-carbon)
- 3 Anode (zinc-gel)
- 4 Nail
- 5 Safety vent
- 6 Negative pole
- 7 Sealing
- 8 Separator
- 9 Cell can
- 10 Cover

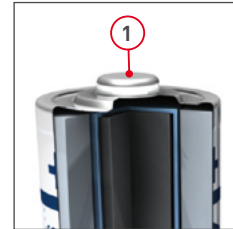
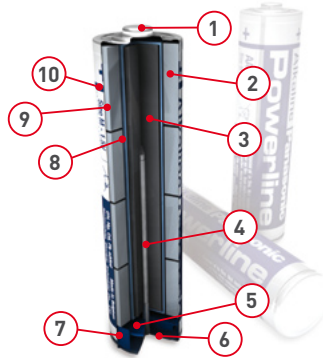

ZINC-CARBON The Zinc-Carbon chemistry is a predecessor of the Alkaline battery technology. It is a standard solution for many different applications which do not require high voltages and extraordinary performance characteristics. Panasonic's long production experience has led to the best performance based on the technological prerequisites.



PRIMARY 1.5 V · 9 V

| Model Number | Size | Nominal Voltage (V) | Dimensions (mm) | | Approx. Weight (g) |
|--------------|------|---------------------|-----------------|--------|--------------------|
| | | | Diameter | Height | |
| R03 | AAA | 1.5 | 10.5 | 44.5 | 8.0 |
| R6 | AA | 1.5 | 14.5 | 50.5 | 19.0 |
| R14 | C | 1.5 | 26.2 | 50 | 49.0 |
| R20 | D | 1.5 | 34.2 | 61.5 | 106.0 |
| 6F22 | 9V | 9 | 17.5 x 26.5 | 48.5 | 38.0 |

Applications

Alarm clocks, Remote Controls, Radios, Energy saving flashlights etc.

Features/Technology

- Established and reliable battery technology
- Outstanding price versus quality ratio
- Economical in terms of cost per hour for low current consumption

ZINC-CARBON • 3D ILLUSTRATION

- 1 Positive pole
- 2 Polyethylene gasket
- 3 Cover
- 4 Carbon stick
- 5 Cathode (manganese)
- 6 Negative pole
- 7 Insulator
- 8 Anode (zinc can)
- 9 Paper plate

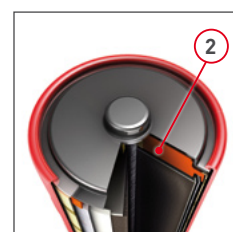
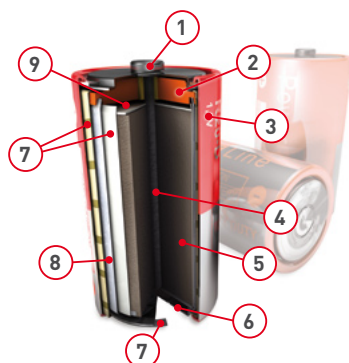

VALVE-REGULATED (SEALED)-LEAD-ACID

BATTERY TYPES AND MODEL NUMBERS

| | | |
|-----------------------------------|--|--|
| For main power source | Cycle Long Life type → LC-XC, LC-C | |
| For main and standby power source | Trickle Design Life 6–9 years → LC-R, LC-V | |
| For standby power source | Trickle Design Life 6–9 years → UP-RW | Standard case → LC-X, LC-XB, LC-XD Flame-retardant case → LC-P, UP-PW |
| | Trickle Design Life 10–12 years | |
| | Trickle Design Life 17 years → LC-QA | |

Trickle Design Life:
 → Temperature: 20°C
 → Discharge current: 0.1 CA
 → Discharge ending voltage:
 5.4 V for 6 V battery,
 10.8 V for 12 V battery
 → Charge voltage:
 6.85 V for 6 V battery,
 13.7 V for 12 V battery
 → Trickle Design Life conform to Eurobat.

LC SERIES Panasonic LC series (Valve-Regulated-Lead-Acid battery) was developed by studying and analysing the factors which cause deterioration of conventional batteries in various aspects. The results of this analysis are reflected in our continuous battery development activities. The Panasonic LC series is available with a trickle design life of 6–9 years and 10–12 years on the one hand and so-called long life cycle types for main power supply on the other. The majority of our VRLA batteries are available with different types of terminals.



CYCLE LONG LIFE

RECHARGEABLE 12 V

| Model Number | Nominal Voltage (V) | Rated Capacity (Ah) 20 hours rate | Dimensions (mm) | | | | Mass approx. (kg) | VdS VdS N° |
|--------------|---------------------|--------------------------------------|-----------------|-------|--------|----------------------|-------------------|---------------|
| | | | Length | Width | Height | Approx. Total Height | | |
| LC-CA1212P | 12 | 12 | 151 | 98 | 94 | 100 | 3.80 | - |
| LC-CA1215P | 12 | 15 | 151 | 98 | 94 | 100 | 4.20 | - |
| LC-XC1222AP | 12 | 22 | 181 | 76 | 167 | 167 | 6.50 | - |
| LC-XC1228P | 12 | 28 | 165 | 125 | 175 | 179.5 | 10.00 | - |
| LC-XC1238P | 12 | 38 | 197 | 165 | 175 | 179.5 | 15.00 | - |

TRICKLE DESIGN LIFE 6 – 9 YEARS

RECHARGEABLE 6 V · 12 V

| Model Number | Nominal Voltage (V) | Rated Capacity (Ah) 20 hours rate | Dimensions (mm) | | | | Mass approx. (kg) | VdS VdS N° |
|--------------|---------------------|--------------------------------------|-----------------|-------|--------|----------------------|-------------------|---------------|
| | | | Length | Width | Height | Approx. Total Height | | |
| LC-R061R3P | 6 | 1.3 | 97 | 24 | 50 | 55 | 0.30 | - |
| LC-R063R4P | 6 | 3.4 | 134 | 34 | 60 | 66 | 0.62 | - |
| LC-R064R5P | 6 | 4.5 | 70 | 48 | 102 | 108 | 0.72 | - |
| LC-R067R2P | 6 | 7.2 | 151 | 34 | 94 | 100 | 1.26 | - |
| LC-R0612P | 6 | 12 | 151 | 50 | 94 | 100 | 2.00 | - |
| LC-R0615P | 6 | 15 | 151 | 50 | 94 | 100 | 2.10 | - |
| LC-R121R3PG | 12 | 1.3 | 97 | 47.5 | 50 | 55 | 0.59 | G196049 |
| LC-R122R2PG | 12 | 2.2 | 177 | 34 | 60 | 66 | 0.80 | G188151 |
| LC-R123R4PG | 12 | 3.4 | 134 | 67 | 60 | 66 | 1.20 | G191053 |
| LC-R124R5P | 12 | 4.5 | 70 | 97 | 102 | 108 | 1.45 | - |
| LC-R127R2PG | 12 | 7.2 | 151 | 64.5 | 94 | 100 | 2.47 | G193046 |
| LC-RA1212PG | 12 | 12 | 151 | 98 | 94 | 100 | 3.80 | G100001 |
| LC-RA1215P | 12 | 15 | 151 | 98 | 94 | 100 | 4.20 | - |
| LC-R1233P | 12 | 33 | 195.6 | 130 | 155 | 180 | 12.00 | - |
| LC-V1233P | 12 | 33 | 195.6 | 130 | 155 | 180 | 11.10 | - |



VALVE-REGULATED (SEALED)-LEAD-ACID

TRICKLE DESIGN LIFE 10 – 12 YEARS

RECHARGEABLE 6 V · 12 V

| Model Number | Nominal Voltage (V) | Rated Capacity (Ah) 20 hours rate | Dimensions (mm) | | | | Mass approx. (kg) | VdS VdS N° |
|-------------------------------|---------------------|--------------------------------------|-----------------|-------|--------|---------------------|-------------------|---------------|
| | | | Length | Width | Height | Approx.Total Height | | |
| LC-P067R2P | 6 | 7.2 | 151 | 34 | 94 | 100 | 1.30 | - |
| LC-P0612P | 6 | 12 | 151 | 50 | 94 | 100 | 2.00 | - |
| LC-X06200 | 6 | 200 | 407 | 173 | 210 | 250 | 41.00 | - |
| LC-P122R2P | 12 | 2.2 | 177 | 34 | 60 | 66 | 0.80 | - |
| LC-P123R4P | 12 | 3.4 | 134 | 67 | 60 | 66 | 1.20 | - |
| LC-P127R2P | 12 | 7.2 | 151 | 64.5 | 94 | 100 | 2.50 | - |
| LC-PA1212P | 12 | 12 | 151 | 98 | 94 | 100 | 3.80 | - |
| LC-XD1217PG/APG ^{*1} | 12 | 17 | 181 | 76 | 167 | 167 | 6.50 | G104101 |
| LC-X1220P/AP ^{*1} | 12 | 20 | 181 | 76 | 167 | 167 | 6.60 | - |
| LC-X1224PG/APG | 12 | 24 | 165 | 125 | 175 | 179.5/175 | 9.00 | G198049 |
| LC-X1228P/AP | 12 | 28 | 165 | 125 | 175 | 179.5/175 | 11.00 | - |
| LC-X1238PG/APG | 12 | 38 | 197 | 165 | 175 | 180/175 | 13.00 | G10002 |
| LC-X1242P/AP ^{*1} | 12 | 42 | 197 | 165 | 175 | 180/175 | 16.00 | - |
| LC-X1265PG | 12 | 65 | 350 | 166 | 175 | 175 | 20.00 | G199090 |
| LC-X1275P ^{*1} | 12 | 75 | 350 | 166 | 175 | 175 | 24.00 | - |
| LC-XB12100P ^{*1} | 12 | 100 | 407 | 173 | 210 | 236 | 37.00 | - |
| LC-X12120P | 12 | 120 | 407 | 173 | 210 | 236 | 37.00 | - |



^{*1} This battery is also available with a flame retardant battery case resin (UL94V-0).

Applications

LC Series stand-by applications

UPS,
Communication infrastructure,
Wind turbines,
Alarm systems,
Medical equipment,
Vending machines,
Emergency Lights etc.

Applications

LC Series cyclic applications

Lawn mowers,
Golf-caddies,
Scooters,
E-Bikes,
Wheelchairs,
Toys etc.

Features/Technology LC Series

- State-of-the-art Absorbed Glass Mat (AGM) technology
- Superior design and low spread gives an excellent performance
- Enhanced life-time due to low and stable charge current
- 100% inspection after final assembly and before shipment
- Distinguished production experience
- Selected batteries with flame retardant battery containers according to UL94V-0
- Varied VdS approved batteries

Model Number (example 1)

LC - X 1 2 6 5 P

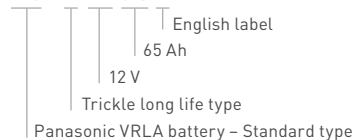

Model Number (example 2)

LC - R 1 2 1 R 3 P G

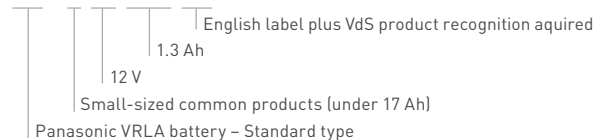

VRLA • 3D ILLUSTRATION

- 1 Gaskets
- 2 Negative plate terminal
- 3 Battery case
- 4 Negative electrode
- 5 Separator
- 6 Positive electrode
- 7 Positive plate terminal
- 8 Valve

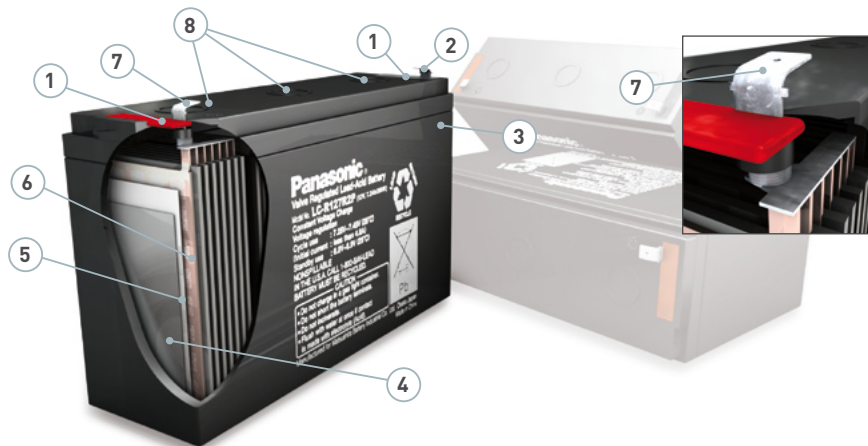

VALVE-REGULATED (SEALED)-LEAD-ACID

UP-RW / PW SERIES The Panasonic UP-RW/PW series offers up to 30% higher energy density compared to conventional VRLA batteries with the same dimensions. Suitable applications are UPS systems which require a short discharge time of about 30 minutes. Long-lasting experience with market leaders in the power supply business field are evidence for the high-performance of this battery series.



RECHARGEABLE 6 V · 12 V

TRICKLE DESIGN LIFE 6 - 9 AND 10 - 12 YEARS

| Model Number | Nominal Voltage (V) | Rated Power (W) | Expected Trickle Design Life (at 20°C) | Dimensions (mm) | | | Approx. Total Height | Mass approx. (kg) | VdS VdS N° |
|-----------------|---------------------|-----------------|--|-----------------|-------|--------|----------------------|-------------------|------------|
| | | 10 minutes rate | | Length | Width | Height | | | |
| UP-RW0645P | 6 | 135 | 6 - 9 years | 151 | 34 | 94 | 100 | 1.30 | - |
| UP-RW1220P | 12 | 120 | 6 - 9 years | 140 | 38.5 | 94 | 100 | 1.35 | - |
| UP-RWA1232P1/P2 | 12 | 192 | 6 - 9 years | 151 | 51 | 94 | 100 | 2.00 | - |
| UP-RW1245P | 12 | 270 | 6 - 9 years | 151 | 64.5 | 94 | 100 | 2.60 | - |
| UP-PW1245P | 12 | 270 | 10 - 12 years | 151 | 64.5 | 94 | 100 | 2.60 | - |

Applications
UPS systems

Features/Technology

- 30% higher energy density compared to conventional VRLA batteries
- Superior quality
- 100% inspection after final assembly and before shipment
- Distinguished production experience
- Batteries with flame retardant battery container according to UL94V-0 available

Model Number (example)

U P - R W 1 2 2 0 P 1

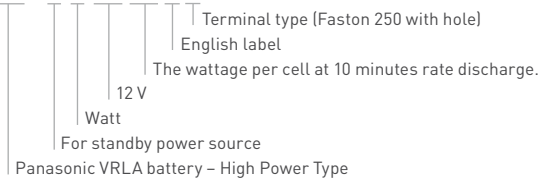

LC-QA SERIES The hallmarks of the Panasonic LC-QA battery series are a very long service life of 17 years (at 20°C) and excellent product quality. The latest LC-QA models are the result of a research programme to prolong the service life of lead-acid batteries, which Panasonic started back in 1984.



RECHARGEABLE 6 V · 12 V

TRICKLE DESIGN LIFE 17 YEARS

| Model Number | Nominal Voltage (V) | Rated Capacity (Ah) | Dimensions (mm) | | | Approx. Total Height | Mass approx. (kg) | VdS VdS N° |
|--------------|---------------------|---------------------|-----------------|-------|--------|----------------------|-------------------|------------|
| | | 20 hours rate | Length | Width | Height | | | |
| LC-QA06200 | 6 | 200 | 407 | 173 | 210 | 250 | 37 | - |
| LC-QA1224 | 12 | 24 | 165 | 125 | 175 | 175 | 10 | - |
| LC-QA1242 | 12 | 42 | 197 | 165 | 175 | 180 | 16 | - |
| LC-QA1265 | 12 | 65 | 350 | 166 | 175 | 175 | 24 | - |
| LC-QA12100 | 12 | 100 | 407 | 173 | 210 | 236 | 37 | - |
| LC-QA12120 | 12 | 120 | 407 | 173 | 210 | 236 | 44 | - |

Applications

Mainly telecommunications industry,
Emergency light for trains,
UPS systems,
Energy Distribution

Features/Technology

- Innovative lead-calcium tin alloy minimises harmful corrosion to the positive electrode
- Reliable seal thanks to a rubber washer and epoxy resin
- Highly flame-retardant housing according to UL 94-V0

TERMINAL TYPES Panasonic offers the appropriate terminal type for each VRLA battery depending on the technical prerequisites. Additionally, some batteries are available with different terminal alternatives.

TERMINAL TYPES (EXAMPLES)

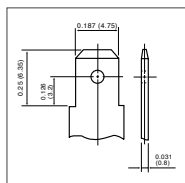

Faston tab type 187

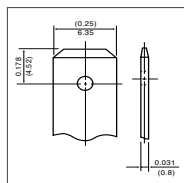

Faston tab type 250

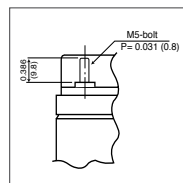

M5 threaded post type

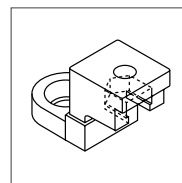

T-shape terminal (M10)

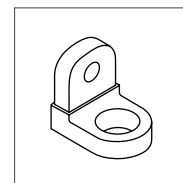

L-shape terminal (M5, 6, 8)

MEMORY CARDS

MEMORY CARDS Nowadays, memory back-up is becoming more and more crucial for all enterprises, especially when data has to be stored and analysed under tough ambient conditions. Panasonic offers memory cards in high-speed and low-speed configurations, as well as with different capacities and shapes.

FULL-SIZE FLASH MEMORY CARD

| CARDS | | | | | | | | |
|--------------|-----------------------|--------------------------|------------------|---------------------|----------------------------|--------------------------|-------------------------------------|----------------|
| Parts Number | Common Memory (bytes) | Attribute Memory (bytes) | Access time (ns) | Current Consumption | Operating Temperature (°C) | Storage Temperature (°C) | Dimensions (mm) | Number of Pins |
| BN-08MHFCC | 8M | EEPROM:8K | 250 | Max. 150 | 0 to 60 | -30 to 80 | PC Card TYPE 1 85.6 * 54.0 * 3.3 | 68 |



FULL-SIZE SRAM CARD

| CARDS | | | | | | | | |
|--------------|-------------------------|------------------|---------------------|----------------------|-------------|----------------------------|--------------------------|-------------------|
| Parts Number | Memory Capacity (bytes) | Access time (ns) | Current Consumption | Battery Life [25 °C] | Sub Battery | Operating Temperature (°C) | Storage Temperature (°C) | Dimensions (mm) |
| BN-064HSR | 64K | 200 | Max. 150 | 5 years | Built-in | 0 to 60 | -20 to 70 | |
| BN-128HSR | 128K | 200 | Max. 150 | 5 years | Built-in | 0 to 60 | -20 to 70 | |
| BN-256HSR | 256K | 200 | Max. 150 | 5 years | Built-in | 0 to 60 | -20 to 70 | |
| BN-512HSR | 512K | 200 | Max. 150 | 5 years | Built-in | 0 to 60 | -20 to 70 | PC Card TYPE 1 |
| BN-01MHSR | 1M | 200 | Max. 150 | 5 years | Built-in | 0 to 60 | -20 to 70 | 85.6 * 54.0 * |
| BN-02MHSR | 2M | 200 | Max. 150 | 3 years | Built-in | 0 to 60 | -20 to 70 | 3.3 |
| BN-04MHSR | 4M | 200 | Max. 150 | 1 year | Built-in | 0 to 60 | -20 to 70 | |
| BN-08MHSR | 8M | 200 | Max. 150 | 6 months | Built-in | 0 to 60 | -20 to 70 | |



Applications

Industry computers,
Metering equipment,
Weather station,
Bus timetables for public transportation

Parts Number (example)

BN-01MHSR

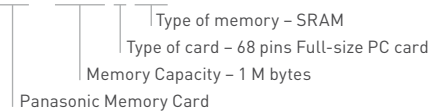

PC CARD ADAPTER FOR SMALL PC CARD

| ADAPTER | |
|--------------|-------------------|
| Parts Number | Dimensions (mm) |
| BN-SPCADP | 85.6 * 54.0 * 5.0 |



BATTERY PACKS

Panasonic can provide a broad range of customised battery pack solutions to meet all customers' energy needs. The requirements of the application, such as charge characteristics, available space and operating conditions, determine the type of battery, number of cells and shape of the pack. At Panasonic we are working in particular on the promotion of battery packs which emphasise safety and reliability of the batteries. We can create battery packs to satisfy the unique requirements of each of our customers and are able to design and produce battery packs of nearly all chemistry. Do not hesitate to contact us regarding your specific needs.

SHAPES OF BATTERY PACKS (TYPICAL & STANDARD TYPES)

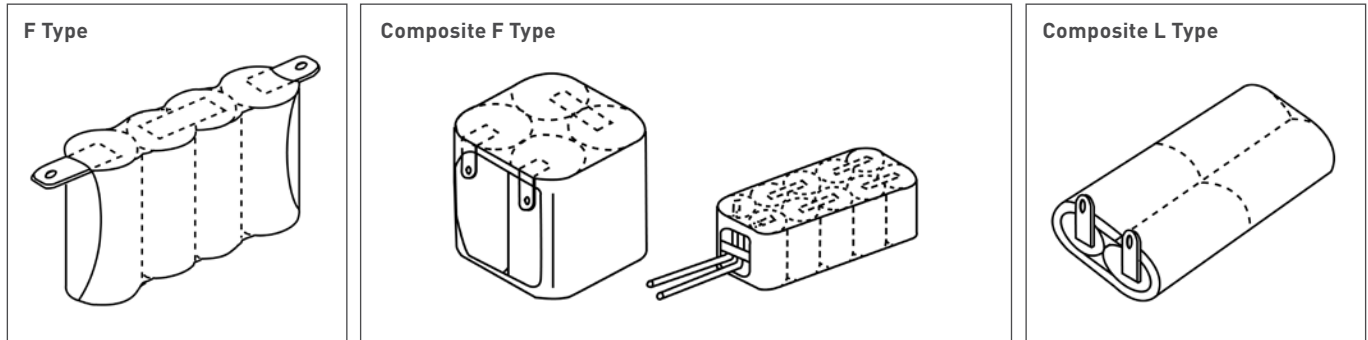

F Type
The required number of single cells are arranged side by side along their diameter connected by nickel plates and packed together with heat-shrinkable tubing.

Composite F Type
Single cells are connected in the F type configuration but in two to five rows rather than one row and packed together by heat-shrinkable tubing.

L Type
The required number of single cells are arranged in a line in the axis of the batteries connected by connecting plates and packed together by heat-shrinkable tubing.

Composite L Type
Single cells connected in the L type configuration are further connected in two to five rows and packed together by heat-shrinkable tubing.

SPECIAL PACK SHAPES

Panasonic can meet customers' needs for customised specifications (such as battery packs in plastic resin cases). Please contact Panasonic for detailed discussions concerning design-in, specifications, lead times etc.

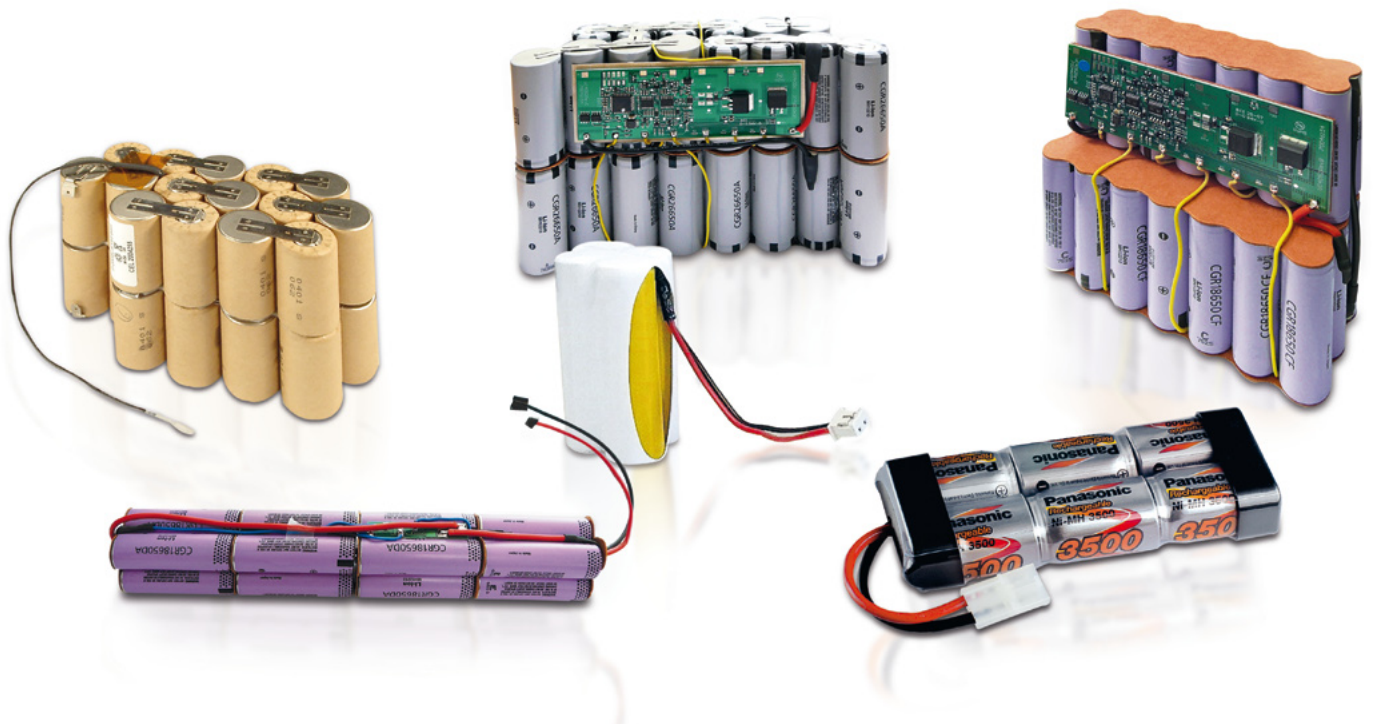

LITERATURE AND GENERAL PRODUCT INFORMATION

United Kingdom/Ireland

Panasonic Industrial Europe GmbH
Willoughby Road
Bracknell Berkshire
RG12 8FP
England
Tel: +44 1344-853260
Fax: +44 1344-853313

Italy

Panasonic Industrial Europe GmbH
Via Lucini 19
20125 Milano
Tel: +39 02-6788-232
Fax: +39 02-6788-207

Spain/Portugal

Panasonic Industrial Europe GmbH
Sucursal en España
Alcalde Barnils, 64-68, Edificio TESTA
Modulo B planta 3a Puerta 2a
08190 Sant Cugat del Valles
Barcelona
Tel: +34 93-5043010
Fax: +34 93-6755892

Germany

(all other european countries)
Panasonic Industrial Europe GmbH
Winsbergring 15
22525 Hamburg
Tel: +49 40-85386-157
Fax: +49 40-85386-238

France

Panasonic Industrial Europe GmbH
1-3 Avenue François Mitterrand
93218 Saint-Denis La Plaine
Tel: +331-55936718
Fax: +331-55936790

E-mail and Website for all countries:

battery-solutions@eu.panasonic.com
www.panasonic-industrial.com/batteries

Notice to Readers

It is the responsibility of each user to ensure that every battery application is adequately designed safe and compatible with all conditions encountered during use, and in conformance with existing standards and requirements.

This literature contains information concerning cells and batteries manufactured by Matsushita Battery Industrial Co., Ltd. This information is generally descriptive only and is not intended to make or imply any representation, guarantee or warranty with respect to any cells and batteries. Cell and battery designs are subject to modification without notice.

For more details please contact:

Panasonic[®]